

SWARCO

McCain FLASHING BEACON CONTROL ASSEMBLY



The McCain Flashing Beacon Control Assembly (FBCA) is designed to control one or two flashing beacons that are used to attract attention to important roadside signs and information. Road safety is heavily reliant on a drivers' compliance with roadside signs, both standard sign panels and electronic signs. Overall roadside safety is enhanced as the solid state flashing beacon increases driver awareness to hidden, changing, or approaching road conditions.



KEY FEATURES AND BENEFITS

- Increases roadside safety by warning drivers of hidden or approaching hazards
- Protects technicians and installers from accidental electrocution with a “dead” front panel
- Comes standard with rugged, NEMA 3R, high-quality housing
- Provides reliable solid state flasher control
- Offers optional dimming and test switches

PRODUCT DESCRIPTION

The McCain FBCA is a rugged and reliable device that can control either a stand-alone or dual flashing beacon as well as beacons connected to McCain Extinguishable Message Signs¹.

The assembly is a NEMA 3R, powder coated, steel housing, featuring solid state electronics and a standard 204 traffic signal flasher unit that controls the flashing signal head(s). Various configurations may include features such as a dimming switch and test switch. Time-of-day activation is also available.

Service input voltage terminated directly at ganged circuit breakers protects field technicians and installers. A double-row terminal block has ample locations for all required wiring.

Flanges on the top and bottom of the housing make installation a snap.

McCain FLASHING BEACON CONTROL ASSEMBLY

FRONT

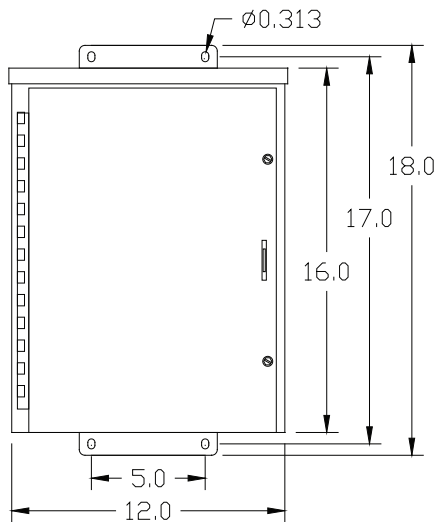

SIDE

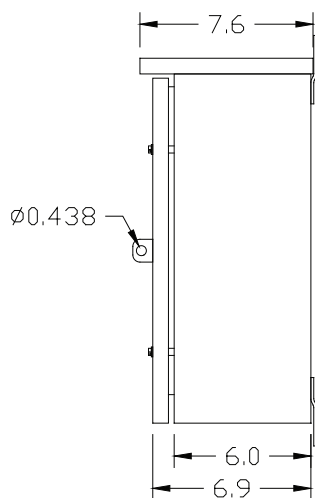

TOP

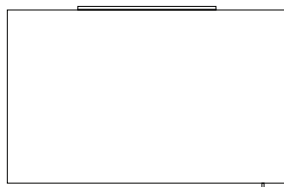

STANDARD FEATURES

- NEMA 3R enclosure
- “Dead” front panel
- Ganged circuit breakers
- Service input voltage terminated directly at circuit breakers
- 204 traffic signal flasher unit
- Dim and test switches where applicable
- Terminal block
- Padlock hasp and 2 latching clasps

GENERAL SPECIFICATIONS

Dimensions ² :	12"W x 16"H x 6"D
Material:	Steel, 14 gauge
Finishes:	Powder coated
Colors:	Sea foam green or custom colors
Environmental:	Operating temperature: -37°C to +74°C Humidity: 0 to 95% (non-condensing)
Shipping Weight ³ :	±25 lbs
Part Numbers:	M53264: FBCA with test switch M53265: FBCA for LED EMS M53269: FBCA with out test switch

OPTIONS

- 365 day solid state programmable time clock
- Time clock module without dimming relay
- EMS control
- Solar powered

Worldwide Distributor



Traffic Signal Division



30 Old Kings Hwy S.
Darien, CT 06820
(800) 947-1464

¹See separate product brochure

²Dimensions rounded to the nearest 0.1"

³An approximation, varies depending on options

www.swarco.com/mccain

SWARCO reserves the right to make changes at any time in order to supply the best product possible.
©SWARCO McCain, Inc. Updated 12/08/2022

